

## “A7H” Series High Pressure Piston Pumps

Enhancing variety of variable piston pumps, 350 Kgf/cm<sup>2</sup> high pressure variable piston pump “A7H Series” is now on market.

### Features

- **High Pressure-Large Volume Displacement**  
Adding to current A3H series, 180 + 270 cm<sup>3</sup>/rev displacement with rated pres. 350 Kgf/cm<sup>2</sup>, Max. Pres. 400 Kgf/cm<sup>2</sup> pumps are now available.
- **Optional Through Drive**  
Optional through drive allows an auxiliary or outboard pump (SAE Standard) to be directly mounted.
- **Fire-Resistant Fluids**  
Water-Glycols and Polyol Ester Type are applicable under certain condition.

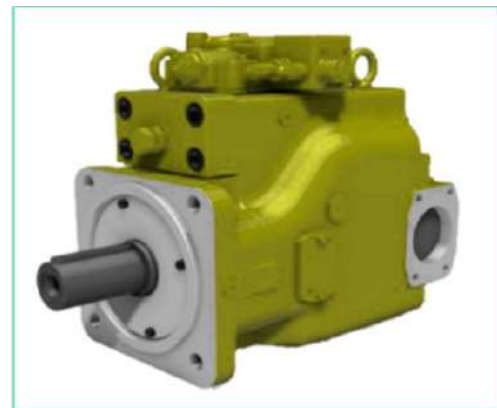

### Specifications

Series Number	Geometric Displacement cm <sup>3</sup> /rev.	Operating Pressure Kgf/cm <sup>2</sup>		Shaft Speed r/min.		Temp. Range °C	Viscosity Range mm <sup>2</sup> /s	Approx. Mass Kg.	
		Rated	Intermittent* <sup>1</sup>	Min.	Max.* <sup>2</sup>			Flange Mtg.	Foot Mtg.
A7H180※※-01-※	180	350	400	1800	1900	-20-80	10-200 (200-1000)* <sup>3</sup>	150	220
A7H180※※-09-※								154	224
A7H265※※-01-※	270	350	400	1200	1600			220	310
A7H265※※-09-※								224	314

\*<sup>1</sup> Consult CNIP for Max. Pres. Operating condition.

\*<sup>2</sup> Max. allowable Shaft Speed is specified when the suction pressure is -0.1 Kgf/cm<sup>2</sup>.

\*<sup>3</sup> When the viscosity is more than 200 mm<sup>2</sup>/s, system is required to be warmed up before operating at rated pressure.

### Specifications for Special Fluids

Types of Fluids	Series Number	Operating Pressure Kgf/cm <sup>2</sup>		Shaft Speed Range r/min.		Temperature Range °C	Viscosity Range mm <sup>2</sup> /s
		Rated	Intermittent* <sup>1</sup>	Min.	Max.* <sup>2</sup>		
Water-Glycols	M-A7H180	210	250	1800	1800	10-50	20-200 (200-1000)* <sup>3</sup>
	M-A7H265	210	250	1200	1200		
Polyol Ester Type	P-A7H180	350	400	1800	1900	10-70	10-200 (200-1000)* <sup>3</sup>
	P-A7H265	350	400	1200	1600		

\*<sup>1</sup> Consult CNIP for Max. Pres. Operating condition.

\*<sup>2</sup> Max. allowable Shaft Speed is specified when the suction pressure is -0.1 Kgf/cm<sup>2</sup>.

\*<sup>3</sup> When the viscosity is more than 200 mm<sup>2</sup>/s, system is required to be warmed up before operating at rated pressure.

### Application

Steel mill equipment, press machines and industrial machines

## Geometric Displacement Adj. Range

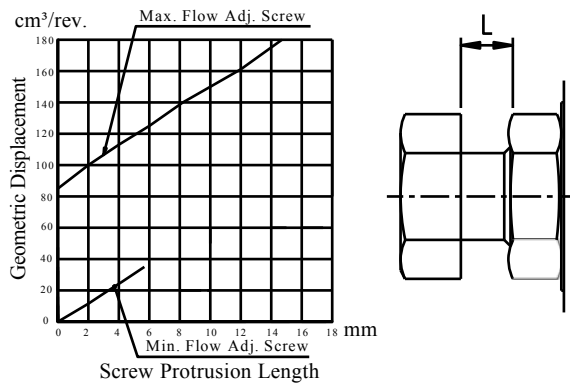

## Performance Characteristics

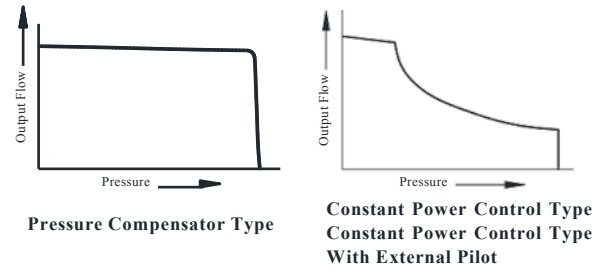

## Control Type and Graphic Symbols

Model Number	Control Type
A7H※-※R01S	Pressure Compensator Type
A7H※-※R09S	Constant Power Control Type
A7H※-※R09RS	Constant Power Control Type With External Pilot

### Graphic Symbols

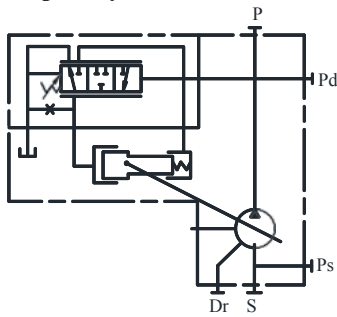

Pressure Compensator Type

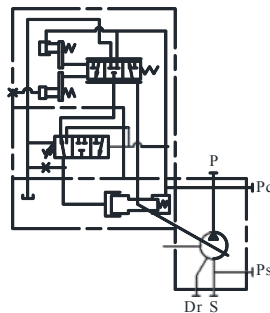

Constant Power Control Type

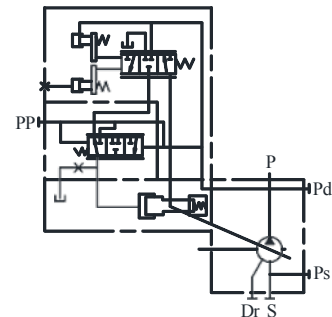

Constant Power Control Type With External Pilot Type

## Model Number Designation

### Pressure Compensator Type

M-	A7H265	-F	R	01	S	N	A	-10
Type of Fluids	Series Number	Mounting	Direction of Rotation	Control Type	Port Position	Pipe Flange	Outboard Pump Mounting Type	Design Number
<b>None:</b> Petroleum Base Oils (Mineral oils)  <b>M:</b> Water-Glycols  <b>P:</b> Polyol EsterType	<b>A7H180:</b> (180cm <sup>3</sup> /rev)  <b>A7H265:</b> (270cm <sup>3</sup> /rev)	<b>F:</b> Flange Mtg.  <b>L:</b> Foot Mtg.	<b>R:</b> Clockwise (Viewed from shaft End)	<b>01:</b> Pressure Compensator Type  (With Min. Flow Adj. Function)	<b>S:</b> Side Port	<b>None:</b> With Pipe Flange  <b>N:</b> Without Pipe Flange	<b>A:</b> SAE A  <b>B:</b> SAE B  <b>C:</b> SAE C  <b>CC:</b> SAE CC  <b>D:</b> SAE D	10

● **Constant Power Control Type and Constant Power Control Type With External Pilot**

M-	A7H265	-F	R	09	R	S	N	A	M1	-10
Type of Fluids	Series Number	Mounting	Direction of Rotation	Control Type	External Pilot	Port Position	Pipe Flange	Outboard Pump Mounting Type	Code of Constant Power Control Type	Design Number
<b>None:</b> Petroleum Base Oils (Mineral oils)  <b>M:</b> Water Glycols  <b>P:</b> Polyol Ester Type	<b>A7H180:</b> (180cm <sup>3</sup> /rev)  <b>A7H265:</b> (270cm <sup>3</sup> /rev)	<b>F:</b> Flange Mtg.  <b>L:</b> Foot Mtg.	<b>R:</b> Clockwise (Viewed from shaft End)	<b>09:</b> Constant Power Control Type	<b>None:</b> Without External Pilot  <b>R:</b> With External Pilot	<b>S:</b> Side Port	<b>None:</b> With Pipe Flange  <b>N:</b> Without Pipe Flange	<b>None:</b> Without Mounting (With End Cover)  <b>A:</b> SAE A <b>B:</b> SAE B <b>C:</b> SAE C <b>CC:</b> SAE CC <b>D:</b> SAE D	Refer to below Code table	10

**Code table of constant power control type**

<A7H180>

<A7H265>

Motor Power kW	970 r/min.	1150 r/min.	1450 r/min.	1750 r/min.	Motor Power kW	970 r/min.	1150 r/min.	1450 r/min.
30	M4	-	-	-	45	M5	-	-
37	M2	M3	-	-	55	M3	M5	-
45	H5	M2	M4	-	75	H3	M1	M4
55	H3	H5	M2	M4	90	H2	H3	M2
75	-	H1	H4	M1	110	-	H1	H4
90	-	-	H2	H4	132	-	-	H2
110	-	-	-	H2				

● **Pipe Flange for Suction**

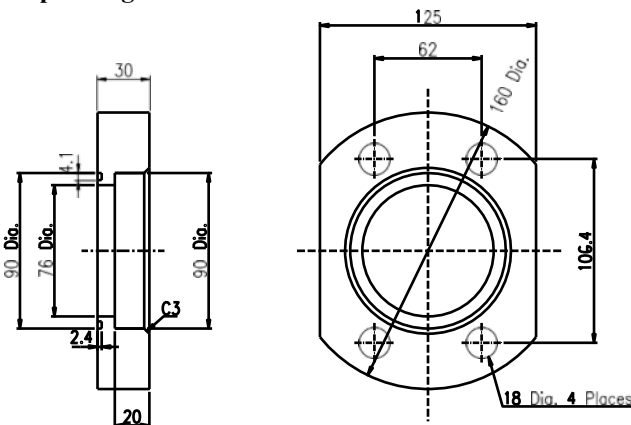

Port	Pipe Size	Bolt Size	O-Ring
Suction	3"	M16 x 50L	SO-NB-G85
Discharge	1 1/2"	M16 x 55L	SO-NB-G45

● **Pipe Flange for Discharge**

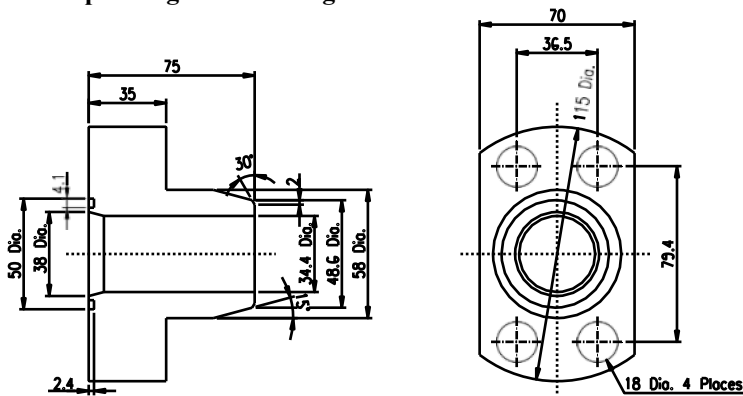

## Performance Characteristics of constant Power Control Type

### A7H180

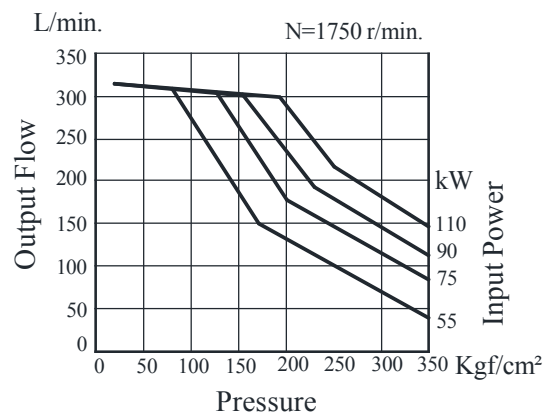
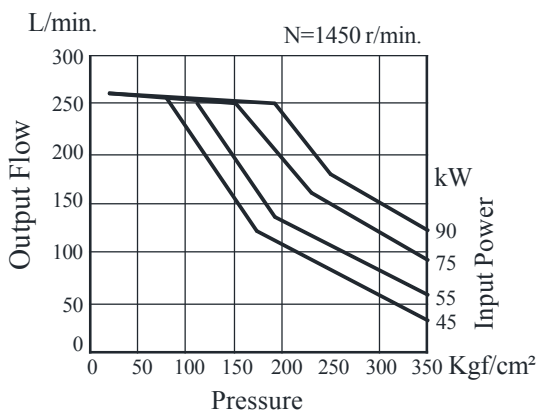
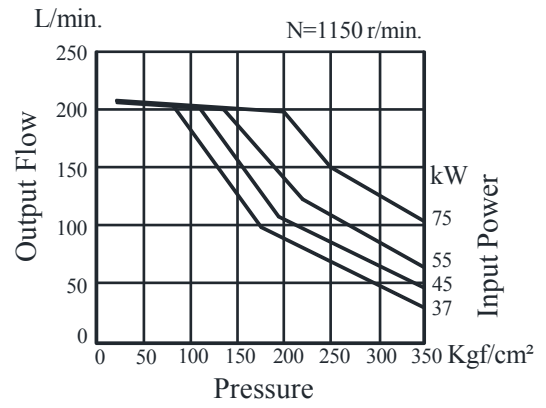
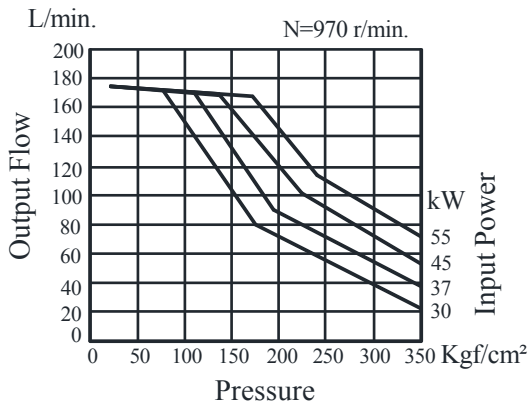

### A7H265

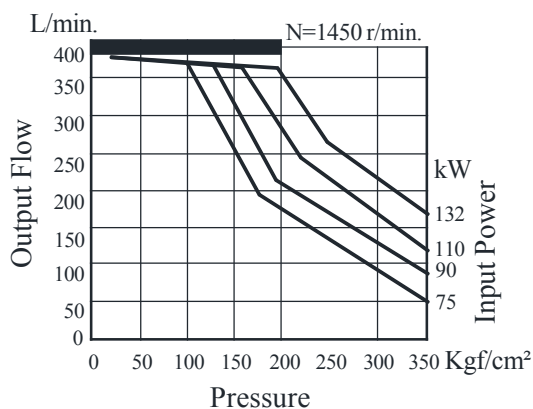
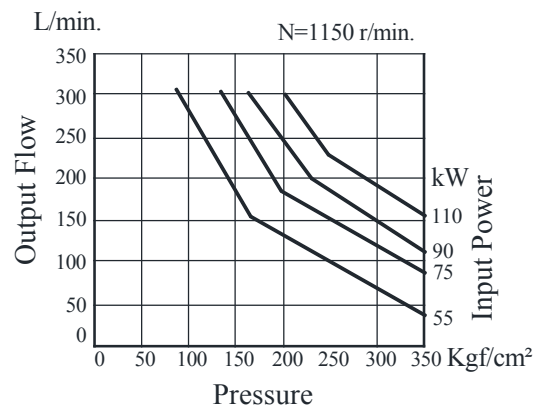
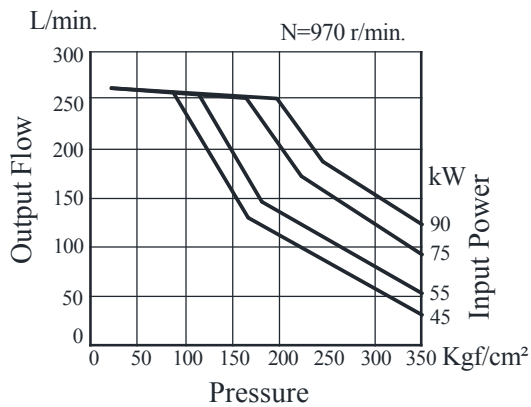

## Typical Performance Characteristics of Type "A7H180" Oil Viscosity 20cSt [ISO VG 32, 50° C]

A

"A3HG" Series High Pressure Variable Displacement Piston Pumps

### Performance Characteristic Curve

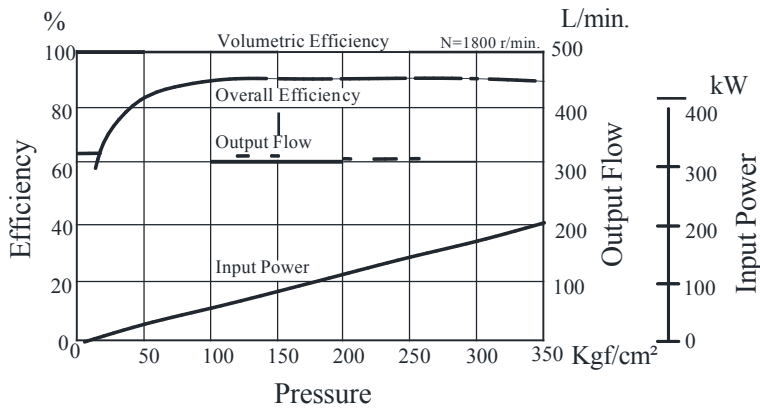

### Full Cut-off Power

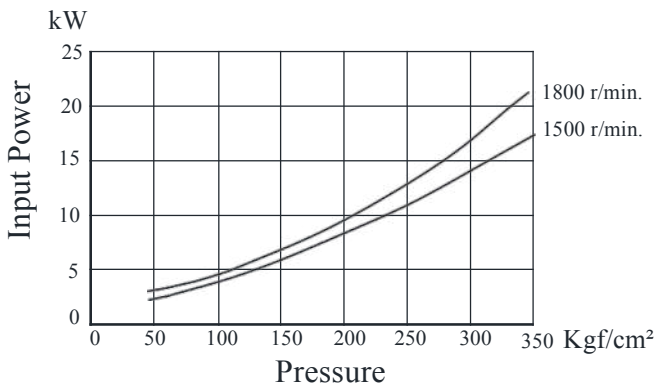

### Drain

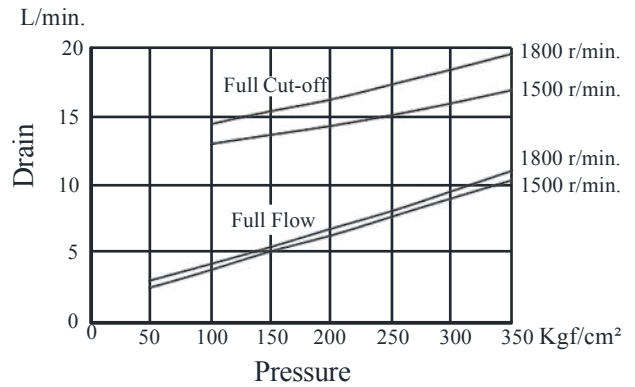

### Suction

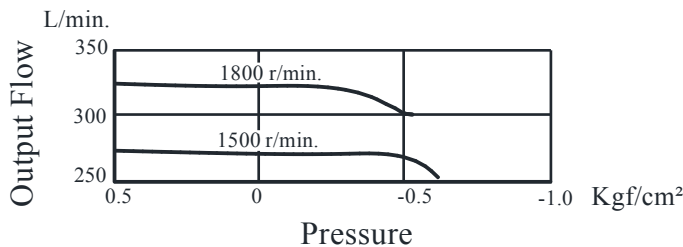

## Typical Performance Characteristics of Type "A7H265" Oil Viscosity 20cSt [ISO VG 32, 50° C]

### Performance Characteristic Curve

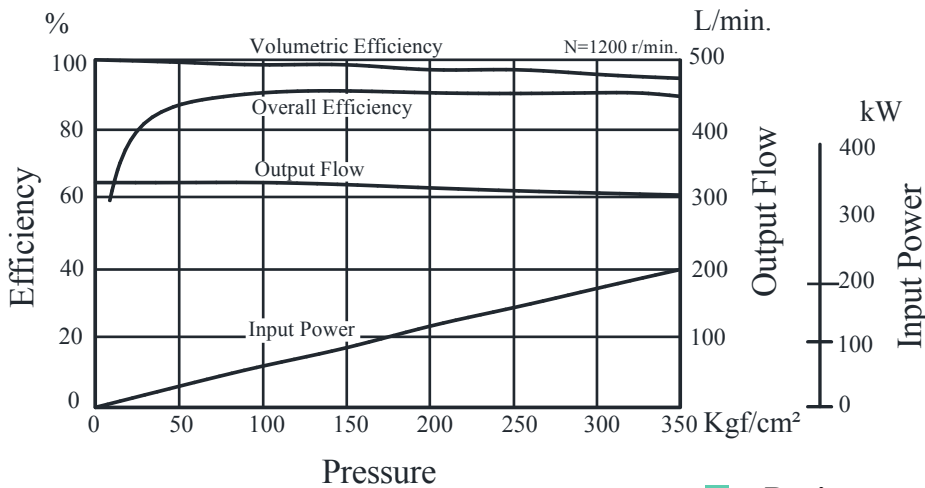

### Full Cut-off Power

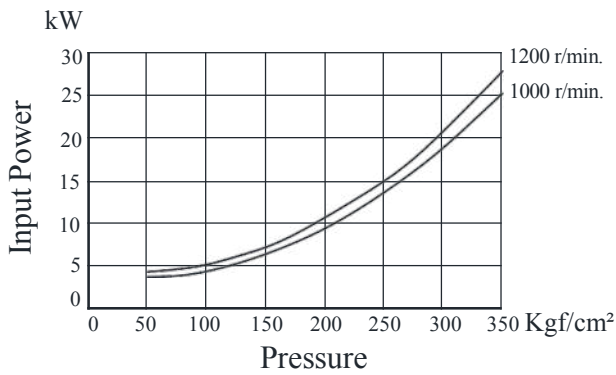

### Drain

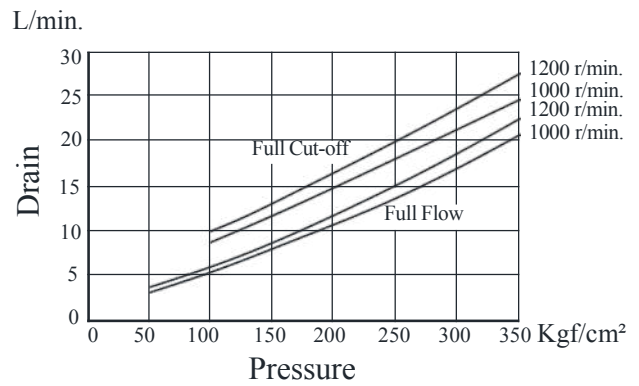

### Suction

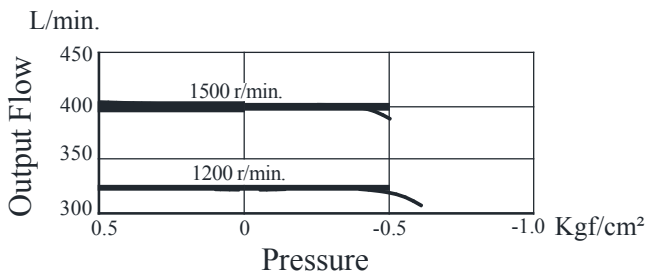

● **A7H180-※※01**

● **Flange Mounting**

● **※-A7H180-FR01S※-**

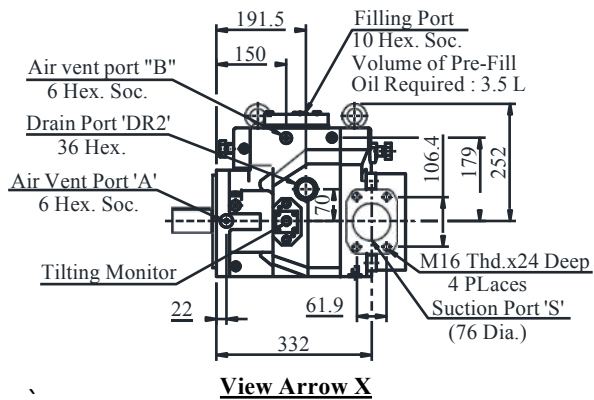
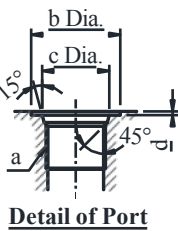
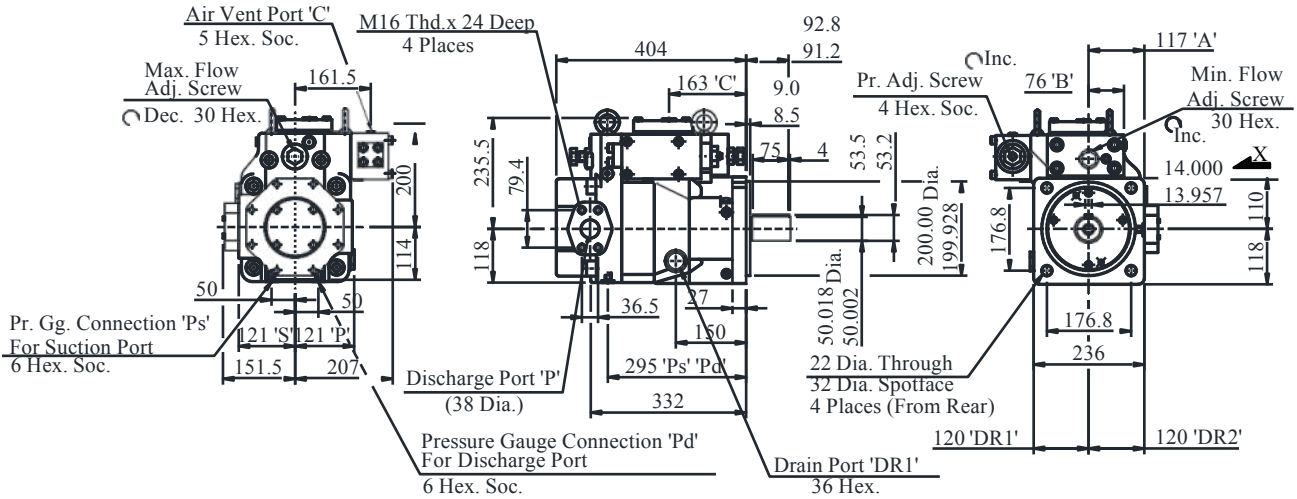

Dimensions	'a'	'b'	'c'	'd'
Pr. Gauge Connection For Suction & Discharge Port	G 1/4'	26	15.6	2.5
Drain Port	G 3/4'	-	30.8	3.5

\* Install the pump so that the "Filling port" is at the top.

**DIMENSIONS IN MILLIMETRES**

● **Foot Mounting type**

● **※-A7H180-LR01S※-**

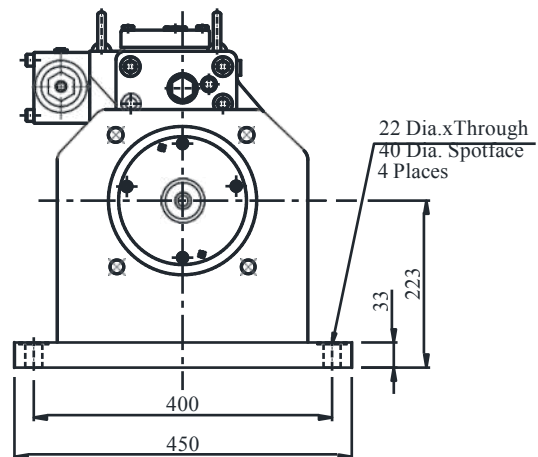
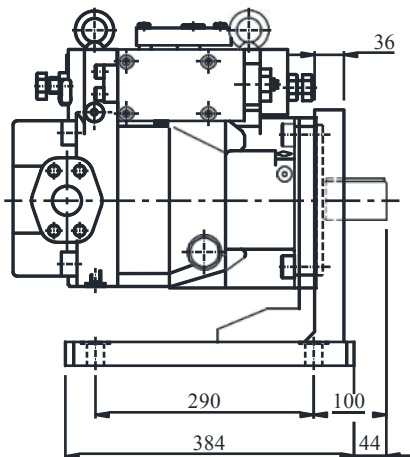

● **A7H180-※※09**

● **Flange Mounting**

● **※-A7H180-FR09S※-※※-**

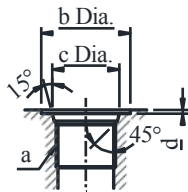
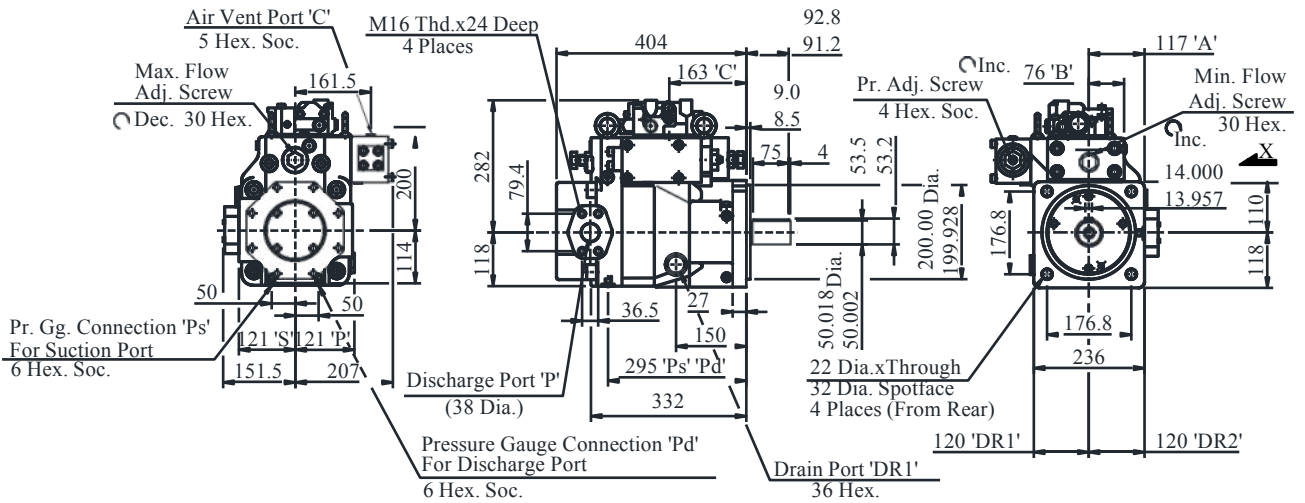

**Detail of Port**

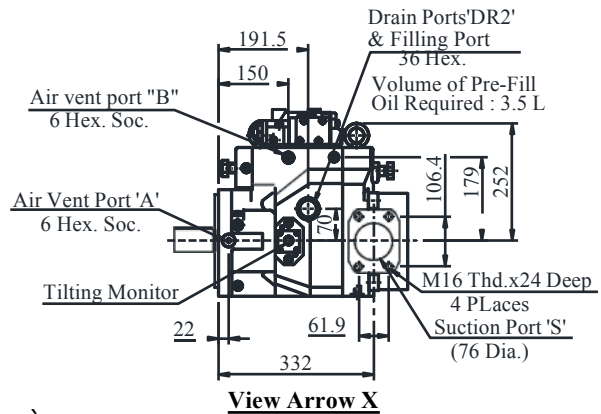

Dimensions	'a'	'b'	'c'	'd'
Pr. Gauge Connection For Suction & Discharge Port	G 1/4'	26	15.6	2.5
Drain Port	G 3/4'	-	30.8	3.5

\* Install the pump so that the "Filling port" is at the top.

**DIMENSIONS IN MILLIMETRES**

● **Foot Mounting type**

● **※-A7H180-LR09S※-※※-**

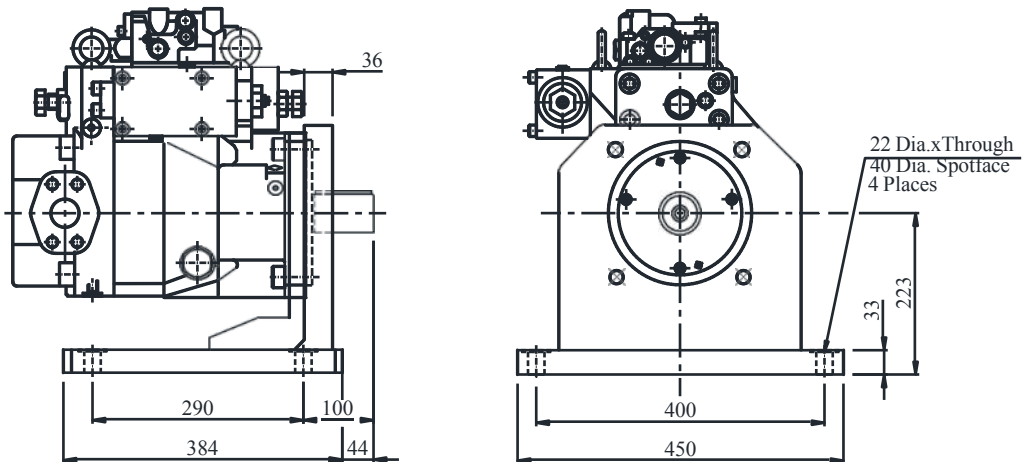



● A7H180-※※09R

● Flange Mounting

● ※-A7H180-FR09RS※-※※

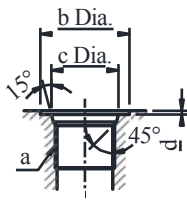
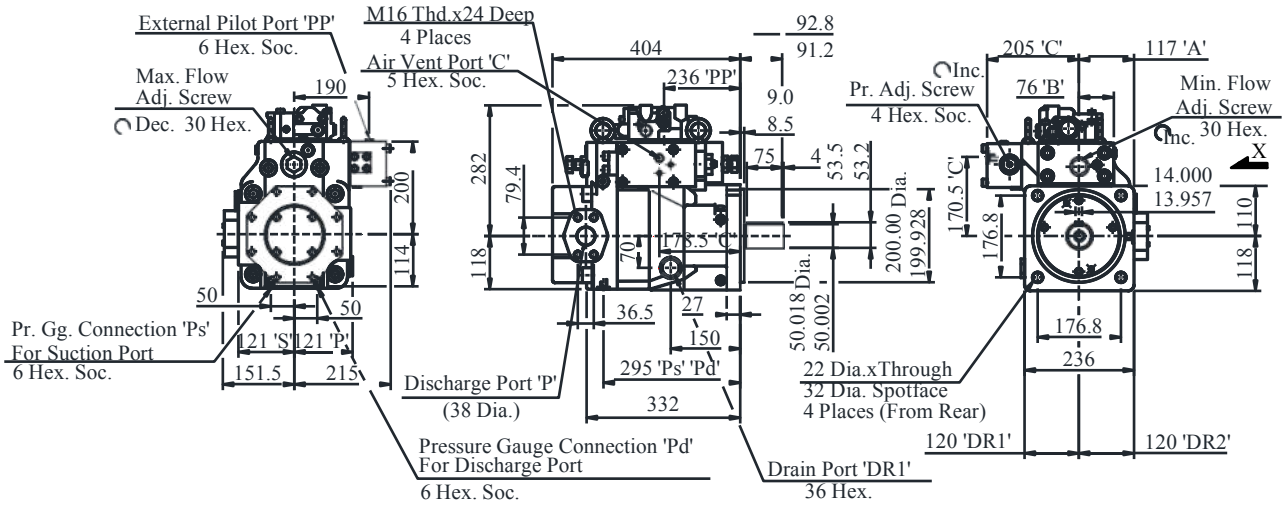

Detail of Port

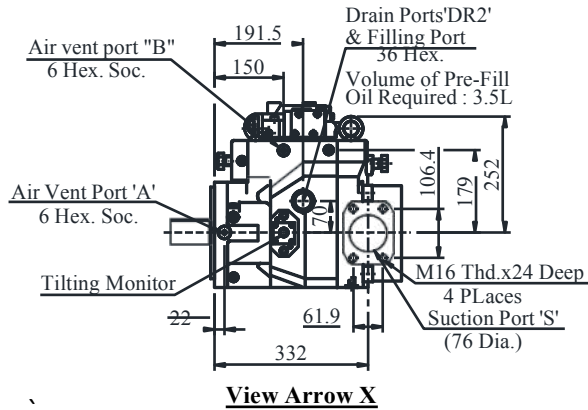

View Arrow X

Dimensions	'a'	'b'	'c'	'd'
Pr. Gauge Connection For Suction & Discharge Port	G 1/4'	26	15.6	2.5
Drain Port	G 3/4'	-	30.8	3.5
External Pilot Port	G 1/4'	24	15.6	2.5

\* Install the pump so that the "Filling port" is at the top.

DIMENSIONS IN MILLIMETRES

● Foot Mounting type

● ※-A7H180-LR09RS※-※※

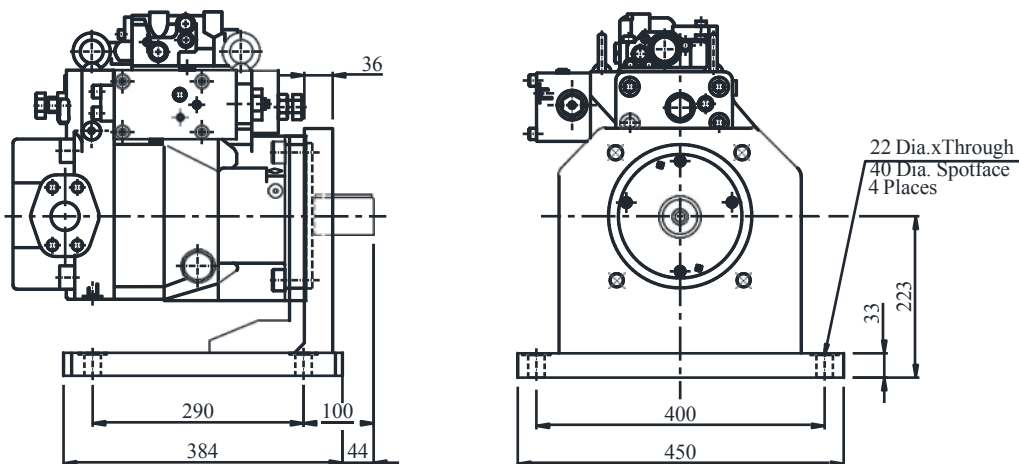



● A7H265-※※09

● ※※-A7H265-FR09S※※-※※

● Flange Mounting

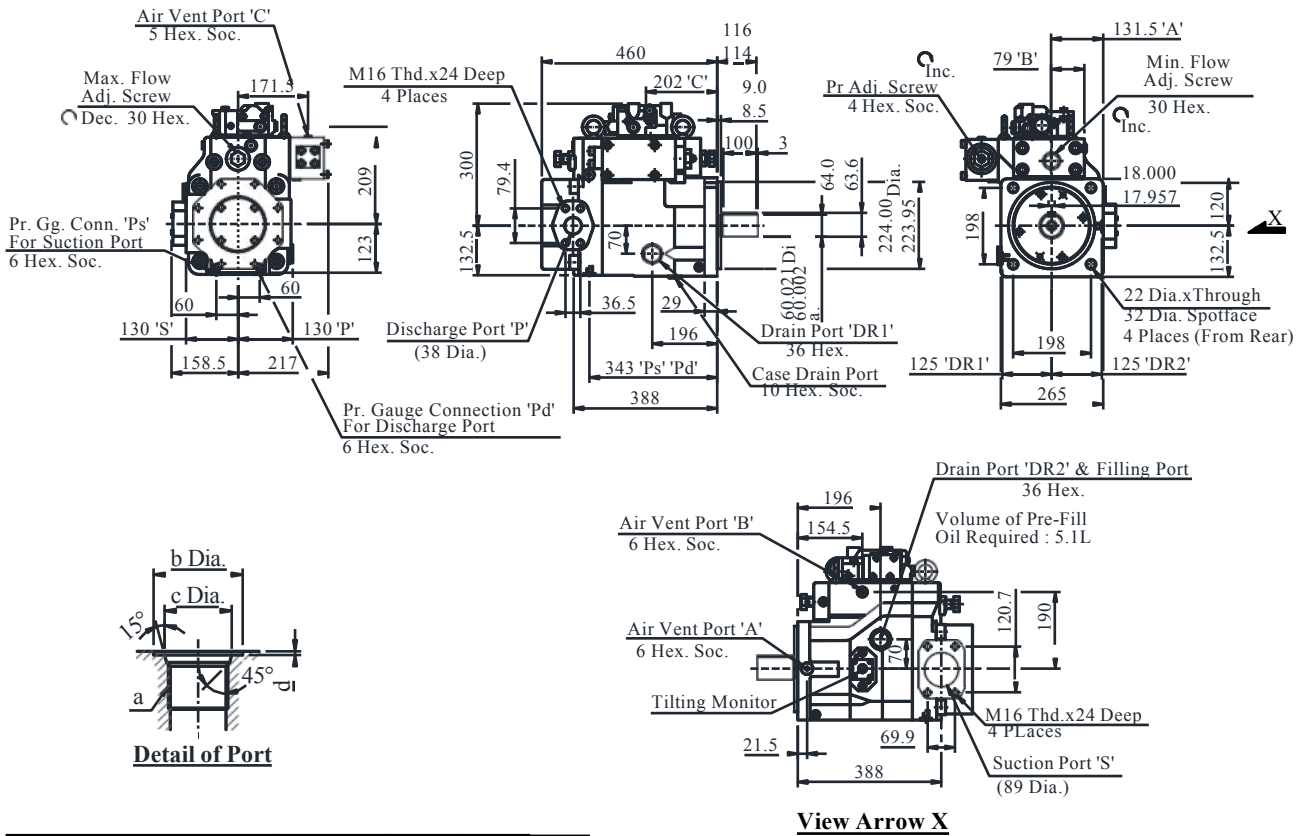

Dimensions	'a'	'b'	'c'	'd'
Pr. Gauge Connection For Suction & Discharge Port	G 1/4'	24	15.6	2.5
Drain Port	G 3/4'	45	30.8	3.5

\* Install the pump so that the "Filling port" is at the top.

DIMENSIONS IN MILLIMETRES

● Foot Mounting type

● ※※-A7H265-LR09S※※-※※

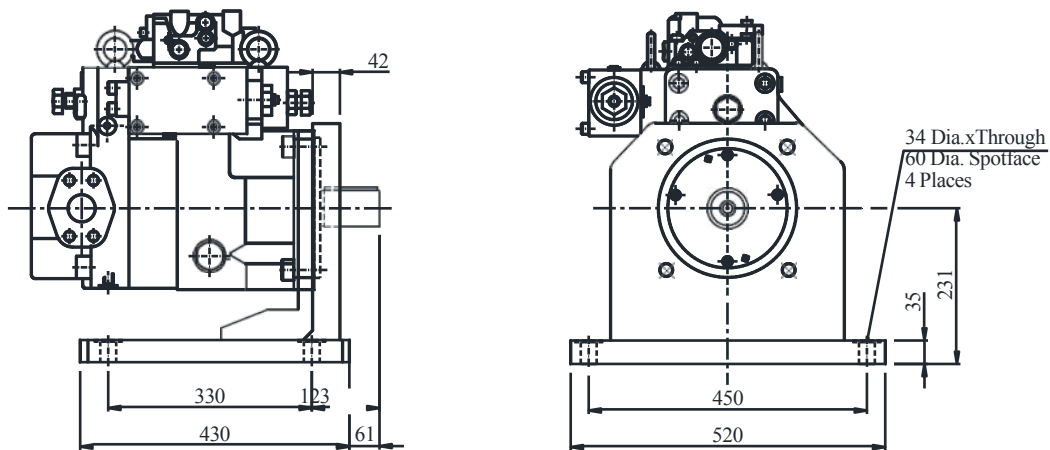

● ※-A7H265-※※09R

● ※-A7H265-FR09RS※-※※-

● Flange Mounting

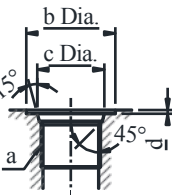
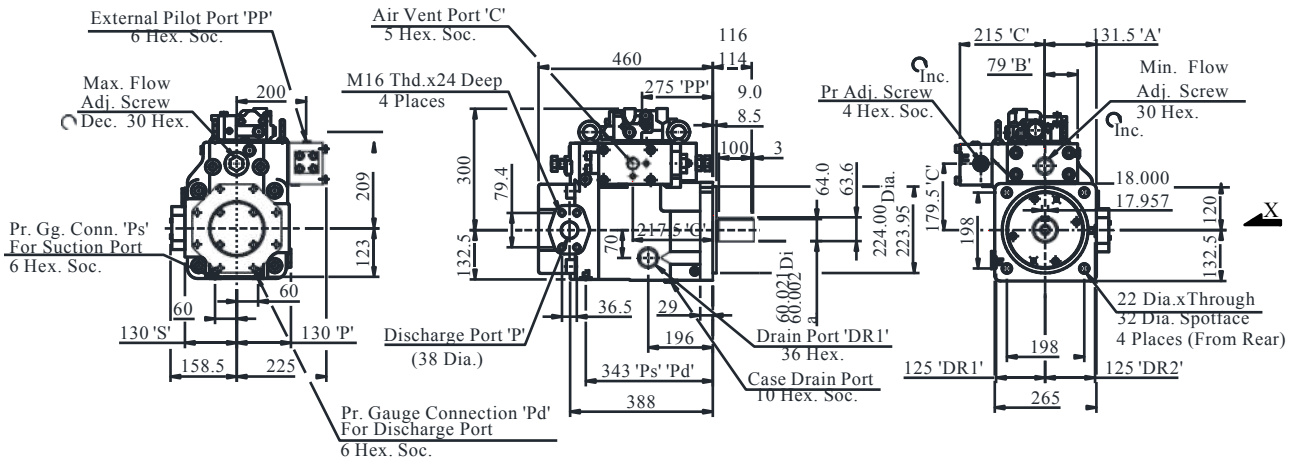

Detail of Port

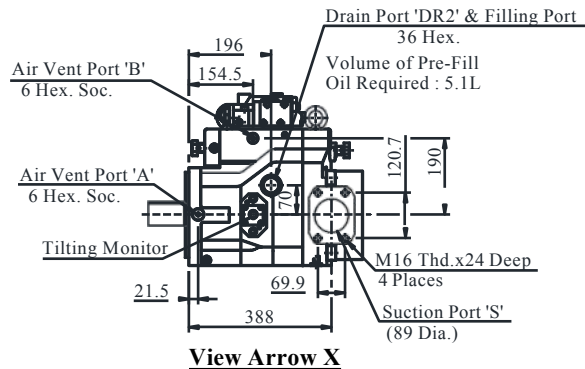

View Arrow X

Dimensions	'a'	'b'	'c'	'd'
Pr. Gauge Connection For Suction & Discharge Port	G 1/4'	24	15.6	2.5
Drain Port	G 3/4'	45	30.8	3.5
External Pilot Port	G 1/4'	24	15.6	2.5

\* Install the pump so that the "Filling port" is at the top.

DIMENSIONS IN MILLIMETRES

● Foot Mounting type

● ※-A7H265-LR09RS※-※※-

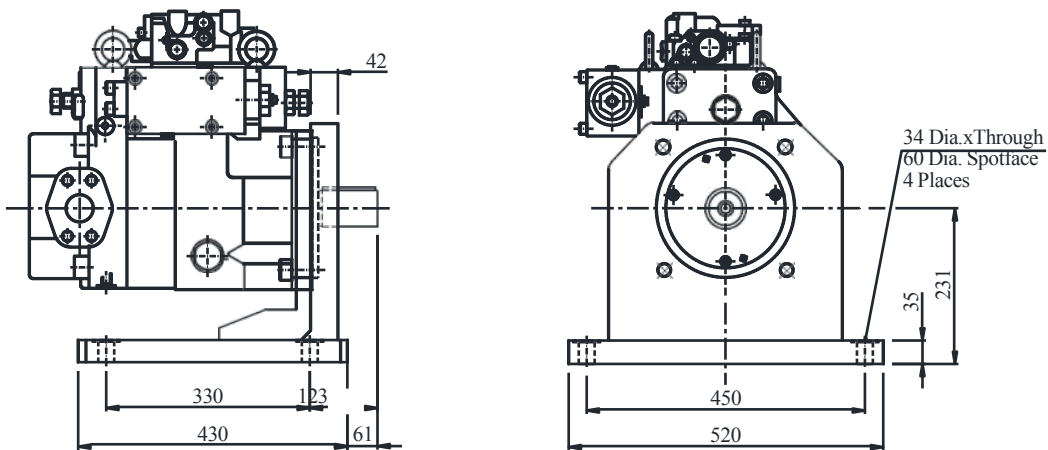

"A7H" Series High Pressure Piston Pumps

## Outboard Pump Mounting Type "A7H180"

Pressure Compensator Type, Constant Power Control Type, Constant Power Control Type with External Pilot is common.

- **※-A7H180-※R01S※A-**
- **Mounting : SAE A (Two - Bolts)**

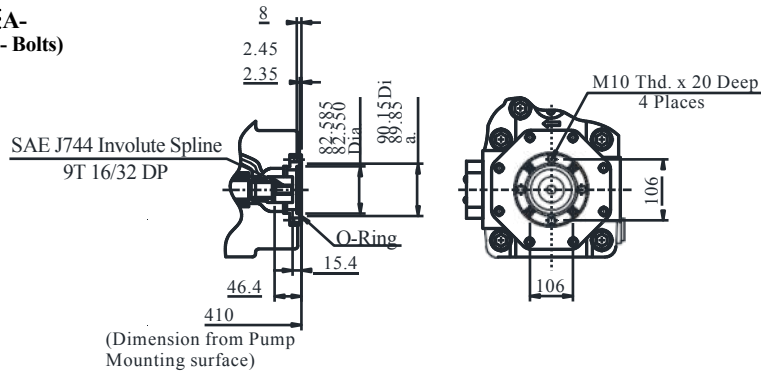

- **※-A7H180-※R01S※B-**
- **Mounting : SAE B (Two - Bolts)**

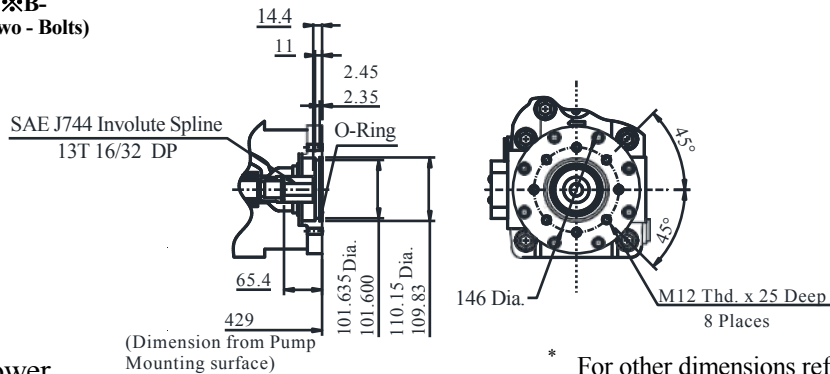

### Allowable Input Power

With a no. 2 pump, There is a limit to the sum of the input power of the inboard and outboard pumps because of shaft and coupling strength. If both pumps are used for boosting at once, referring formulas below, Check that the shaft torques of both pumps are within the allowable range.

$$\frac{T_1}{\text{Inboard Pump}} + \frac{T_2}{\text{Outboard Pump}} \leq 1275 \text{ (N.m)} \quad \text{and} \quad \begin{matrix} T_1 \leq 1000 \text{ (N.m)} \\ T_2 \leq 645 \text{ (N.m)} \end{matrix}$$

**DIMENSIONS IN MILLIMETRES**

\* For other dimensions refer page no.91

- **※-A7H180-※R01S※C-**
- **Mounting : SAE C (Two - Bolts)**

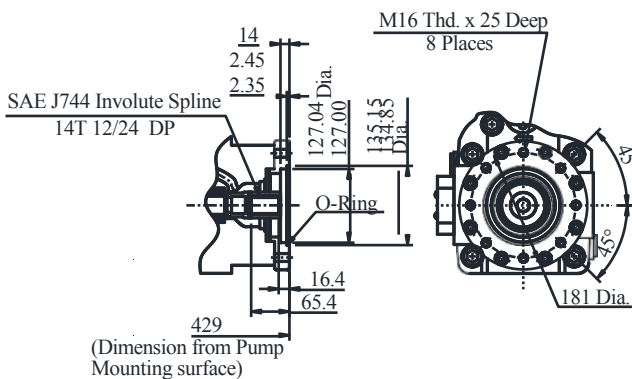

- **※-A7H180-※R01S※CC-**
- **Mounting : SAE CC (Two - Bolts)**

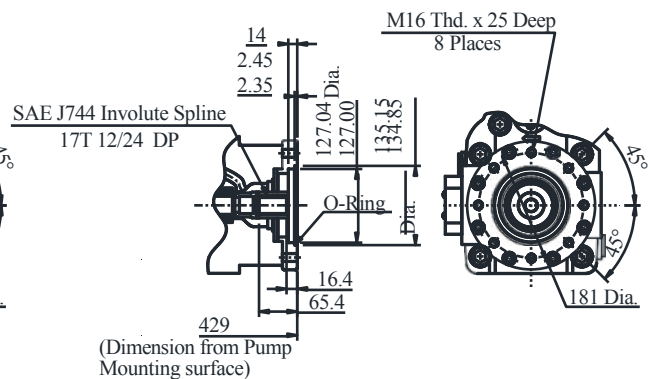

- **※-A7H180-※R01S※D-**
- **Mounting : SAE D (Four - Bolts)**

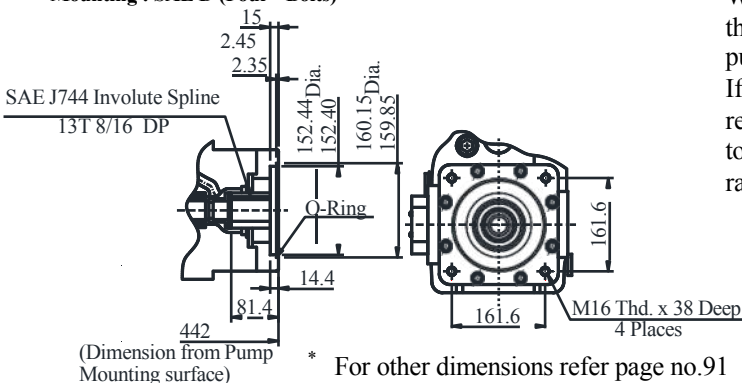

### Allowable Input Power

With a no. 2 pump, There is a limit to the sum of the input power of the inboard and outboard pumps because of shaft and coupling strength. If both pumps are used for boosting at once, referring formulas below, Check that the shaft torques of both pumps are within the allowable range.

$$\frac{T_1}{\text{Inboard Pump}} + \frac{T_2}{\text{Outboard Pump}} \leq 1275 \text{ (N.m)}$$

and

$$\begin{matrix} T_1 \leq 1000 \text{ (N.m)} \\ T_2 \leq 645 \text{ (N.m)} \end{matrix}$$

\* For other dimensions refer page no.91

## "A7H" Series High Pressure Piston Pumps

## Outboard Pump Mounting Type "A7H265"

Pressure Compensator Type, Constant Power Control Type, Constant Power Control Type with External Pilot is common.

- ※-A7H265-※R01S※A-
- Mounting : SAE A (Two - Bolts)

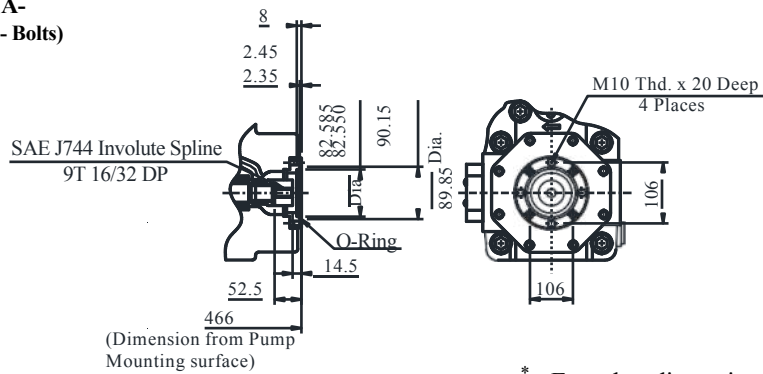

\* For other dimensions refer page no.94

- ※-A7H265-※R01S※B-
- Mounting : SAE B (Two - Bolts)

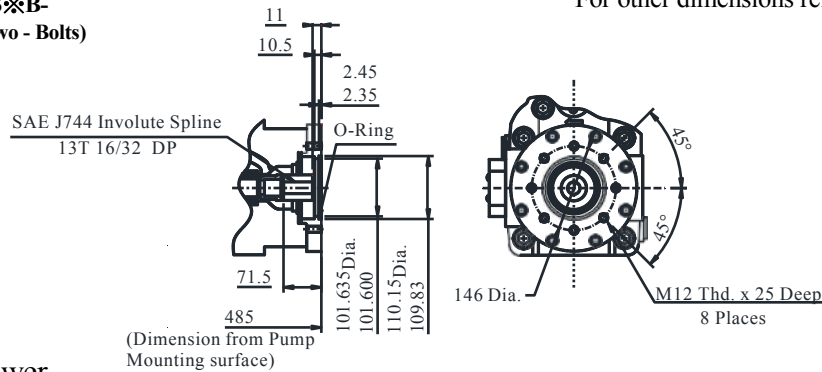

### Allowable Input Power

With a no. 2 pump, There is a limit to the sum of the input power of the inboard and outboard pumps because of shaft and coupling strength. If both pumps are used for boosting at once, referring formulas below, Check that the shaft torques of both pumps are within the allowable range.

$$\frac{T_1}{\text{Inboard Pump}} + \frac{T_2}{\text{Outboard Pump}} \leq 2500 \text{ (N.m)} \quad \text{and} \quad \begin{matrix} T_1 \leq 1500 \text{ (N.m)} \\ T_2 \leq 1000 \text{ (N.m)} \end{matrix}$$

**DIMENSIONS IN MILLIMETRES**

- ※-A7H265-※R01S※C-
- Mounting : SAE C (Two - Bolts)

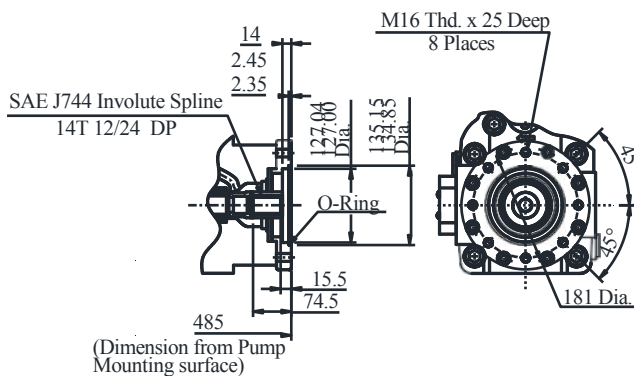

- ※-A7H265-※R01S※CC-
- Mounting : SAE CC (Two - Bolts)

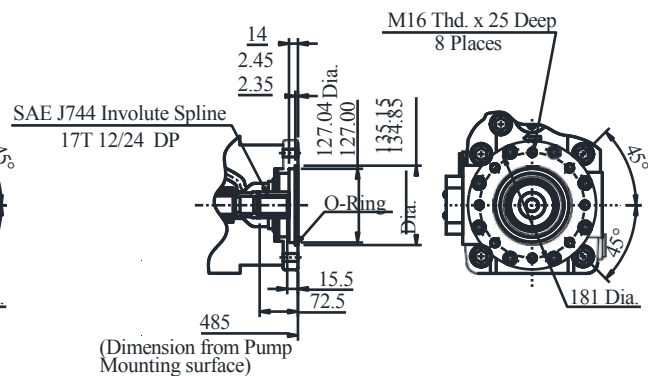

- ※-A7H265-※R01S※D-
- Mounting : SAE D (Four - Bolts)

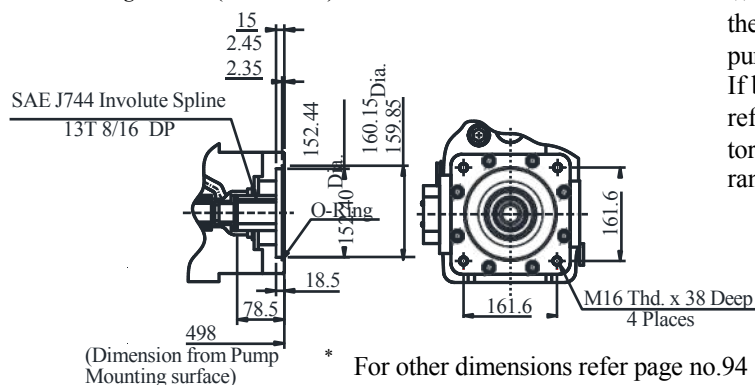

\* For other dimensions refer page no.94

### Allowable Input Power

With a no. 2 pump, There is a limit to the sum of the input power of the inboard and outboard pumps because of shaft and coupling strength. If both pumps are used for boosting at once, referring formulas below, Check that the shaft torques of both pumps are within the allowable range.

$$\frac{T_1}{\text{Inboard Pump}} + \frac{T_2}{\text{Outboard Pump}} \leq 2500 \text{ (N.m)}$$

and

$$\begin{matrix} T_1 \leq 1500 \text{ (N.m)} \\ T_2 \leq 1000 \text{ (N.m)} \end{matrix}$$

## "A7H" Series High Pressure Piston Pumps